

**STRAIGHT PLUG SOLDER TYPE**

**R163.068.125**

**CABLE SHF 8+8M**

Series : N-18

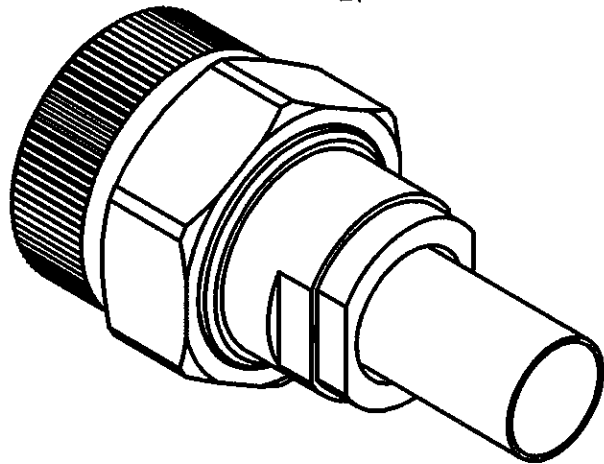
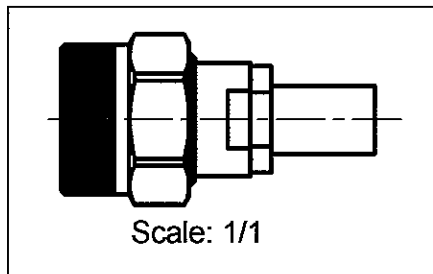
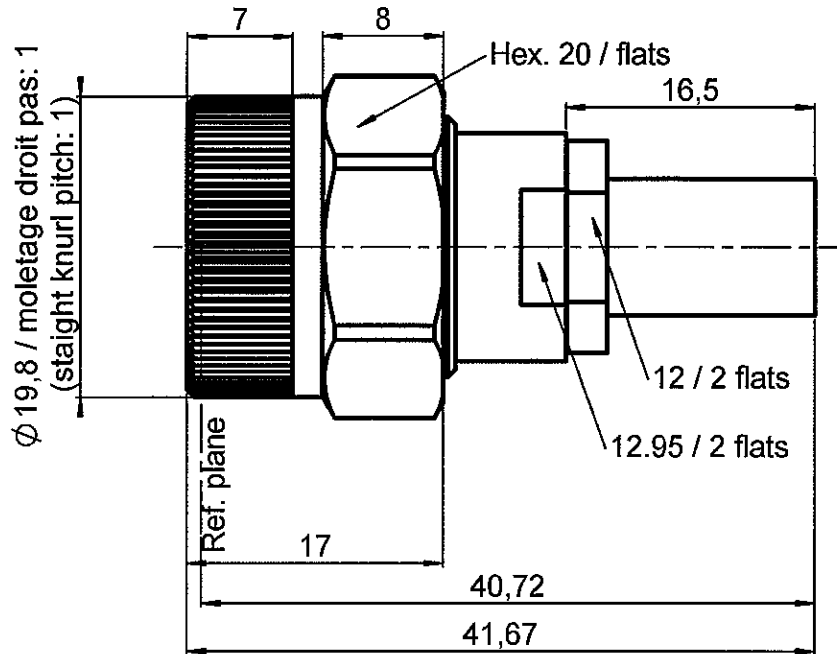

All dimensions are in mm.

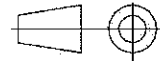

COMPONENTS	MATERIALS	PLATING ( $\mu\text{m}$ )
BODY	BRASS	NICKEL 4
CENTER CONTACT	BRASS	GOLD 0.5 OVER NICKEL 4
OUTER CONTACT	-	-
INSULATOR	PTFE	-
GASKET	FLUOROSILICONE	-
OTHERS PARTS	BRASS	NICKEL 4
-	-	-
-	-	-

Issue : 0520 B

In the effort to improve our products, we reserve the right to make changes judged to be necessary.



**STRAIGHT PLUG SOLDER TYPE**

**R163.068.125**

**CABLE SHF 8+8M**

Series : N-18

**PACKAGING**

Standard	Unit	Other
1	'W' option	Contact us

**SPECIFICATION**

**ELECTRICAL CHARACTERISTICS**

Impedance		<b>50</b> Ω
Frequency		<b>0-18</b> GHz
VSWR	<b>1.1 +</b>	<b>0.000</b> x F(GHz) Maxi
Insertion loss		<b>0.1</b> √F(GHz) dB Maxi
RF leakage	<b>- (</b>	<b>90</b> - F(GHz)) dB Maxi
Voltage rating		<b>500</b> Veff Maxi
Dielectric withstanding voltage		<b>1500</b> Veff mini
Insulation resistance		<b>5000</b> MΩ mini

**CABLE ASSEMBLY**

Stripping	a	b	c	d	e	f
mm	0.00	0.00	0.00	0.00	0.00	0.00

Assembly instruction :

Recommended cable(s)  
F1703-52  
F1703-160

**MECHANICAL CHARACTERISTICS**

Center contact retention		
Axial force – Mating end	<b>27</b>	N mini
Axial force – Opposite end	<b>27</b>	N mini
Torque	<b>NA</b>	N.cm mini

Recommended torque		
Mating	<b>160</b>	N.cm
Panel nut	<b>NA</b>	N.cm
Clamp nut	<b>150</b>	N.cm
A/F clamp nut	<b>0.000</b>	mm

Mating life	<b>500</b>	Cycles mini
Weight	<b>43.963</b>	g

F1703-197

Characteristics indicated on this data sheet are those that can be achieved with the highest performance cable. Intrinsic limitations of the cable may diminish the performance of the assembly

Cable retention

- pull off	<b>60</b>	N mini
- torque		- N.cm

**TOOLING**

Part Number	Description	Hexagon
.	.	.

**ENVIRONMENTAL**

Operating temperature	<b>-65/+165</b>	° C
Hermetic seal	<b>NA</b>	Atm.cm3/s
Panel leakage	<b>NA</b>	

**OTHER CHARACTERISTICS**

Issue : 0520 B

In the effort to improve our products, we reserve the right to make changes judged to be necessary.



**RADIALL®**

N  
N  
N  
N  
N  
N  
N